



Lumex Series FR588W Bariatric Clinical Care Recliner



Operating Instructions

IMPORTANT: READ THIS MANUAL BEFORE OPERATING YOUR LUMEX BARIATRIC FR588W CLINICAL CARE RECLINER.

SAVE THIS MANUAL FOR FUTURE USE.

THE MOST CURRENT VERSION OF THIS MANUAL CAN BE FOUND ONLINE AT www.grahamfield.com.

CONTENTS

INTRODUCTION	3
INTENDED USE	3
IMPORTANT SAFETY PRECAUTIONS—PLEASE READ BEFORE USE	3
WARNINGS	3
PRODUCT DESCRIPTION	5
ASSEMBLY	6
UNPACKING.....	6
SETUP	6
FOOTBOARD INSTALLATION	7
OPERATION	7
SEAT POSITIONING: SHOCK POSITION.....	7
SEAT POSITIONING: HAND PENDANT	8
CASTER OPERATION	8
TABLE OPERATION	8
PRODUCT SPECIFICATIONS.....	9
MAINTENANCE	10
CLEANING	10
LIMITED WARRANTY	11

GF Health Products, Inc. is not responsible for typographical errors. All illustrations, specifications, packaging and warranties contained in this literature are based on the latest product information available at the time of printing. The most current product information, including the most current version of this manual, can be found online at www.grahamfield.com. **Graham-Field** and **Lumex** are registered trademarks of GF Health Products, Inc. © 2007, GF Health Products, Inc., All Rights Reserved.

INTRODUCTION

This manual contains assembly, operation, and maintenance instructions for your Model FR588W Bariatric Clinical Care Recliner. Read the entire manual carefully before using your recliner, and refer to it during use if you have questions.

The Lumex FR588W Bariatric Clinical Care Recliner features a soft seat and back package with wide, soft armrests for improved patient comfort and support during long-term sitting. The easy-to-activate gas cylinder mechanism provides quick Trendelenburg positioning and improved lift.

Intended Use

The Lumex FR588W Bariatric Clinical Care Recliner is intended for use by bariatric patients of all age groups with varying medical and physical conditions. The recliner is ideal for use by clinics, hospitals, and rehabilitation centers.

The Lumex FR588W Bariatric Clinical Care Recliner supports patient weights up to 700 lb. (318 kg) when evenly distributed.

IMPORTANT SAFETY PRECAUTIONS—PLEASE READ BEFORE USE

The safety statements presented in this chapter refer to the basic safety information that the FR588W user shall pay attention to and abide by. There are additional safety statements in other chapters or sections, which may be the same as or similar to the following, or specific to the operations. Please note the following special statements, used throughout this manual, and their significance:

- ⚠ **WARNING:** Indicates a potential hazard situation or unsafe practice that, if not avoided, could result in death or serious personal injury.
- ⚠ **CAUTION:** Indicates a potential hazard or unsafe practice that, if not avoided, could result in minor or moderate personal injury.
- ▲ **NOTICE:** Indicates a potential hazard or unsafe practice that, if not avoided, could result in product or property damage.

Info: Provides application recommendations or other useful information to ensure that you get the most from your product.

WARNINGS

- ⚠ **WARNING:** Periodically inspect all parts and replace as needed.
- ⚠ **WARNING:** Do not use near an open flame, as the chair could be a “combustion source”, resulting in fire, property damage, and severe physical injury.
- ⚠ **WARNING:** Service and repair of the Lumex FR588W Bariatric Clinical Care Recliner must be performed by an authorized Lumex distributor. GF Health Products, Inc. is not responsible for any consequence resulting from any unauthorized service or repair.

- ⚠ WARNING: The electronics and actuator contain no serviceable components. If service is required, the unit must be returned to the factory for repair. DO NOT attempt to open the electronics or actuator or obtain local service; this will void the warranty and may result in damage to the unit. Consult your Lumex dealer for further information.**
- ⚠ WARNING: This product has a maximum weight capacity of 700 lb. (318 kg), EVENLY DISTRIBUTED.**
- ⚠ WARNING: Caster wheels must be locked during occupant transfer.**
- ⚠ WARNING: Unauthorized modification of your recliner or the use of non-Lumex replacement parts may change the structure of the recliner and could create a hazardous condition, which may result in serious injury and will void the warranty.**
- ⚠ WARNING: Notice for California Customers- California Proposition 65 WARNING: This product contains a chemical known to the State of California to cause cancer and reproductive or developmental harm.**
- ⚠ WARNING: GF Health Products, Inc. specifically disclaims responsibility for any bodily injury or property damage which may occur during any use which does not comply with federal, state or local laws or ordinances.**

PRODUCT DESCRIPTION

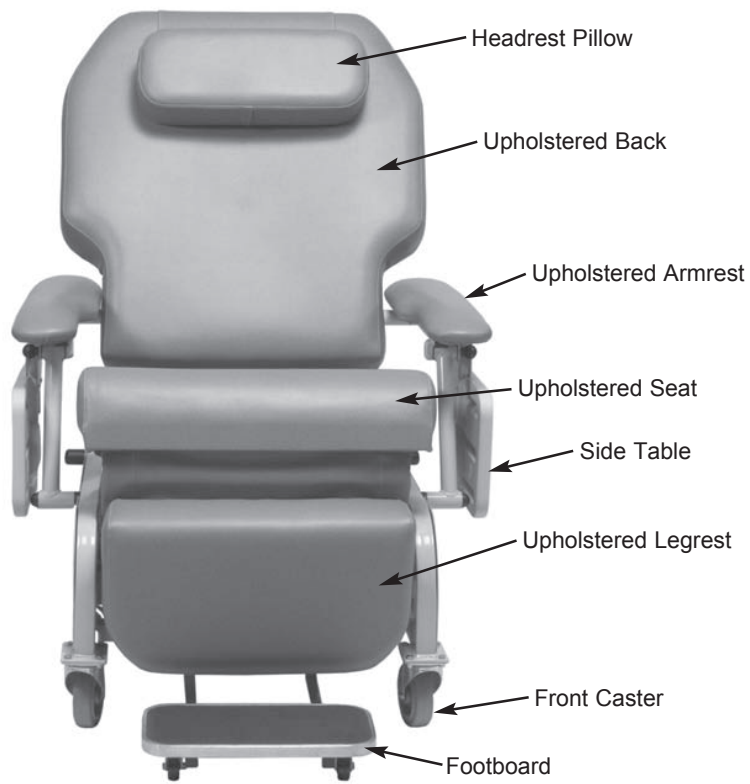

Figure 1



Figure 3

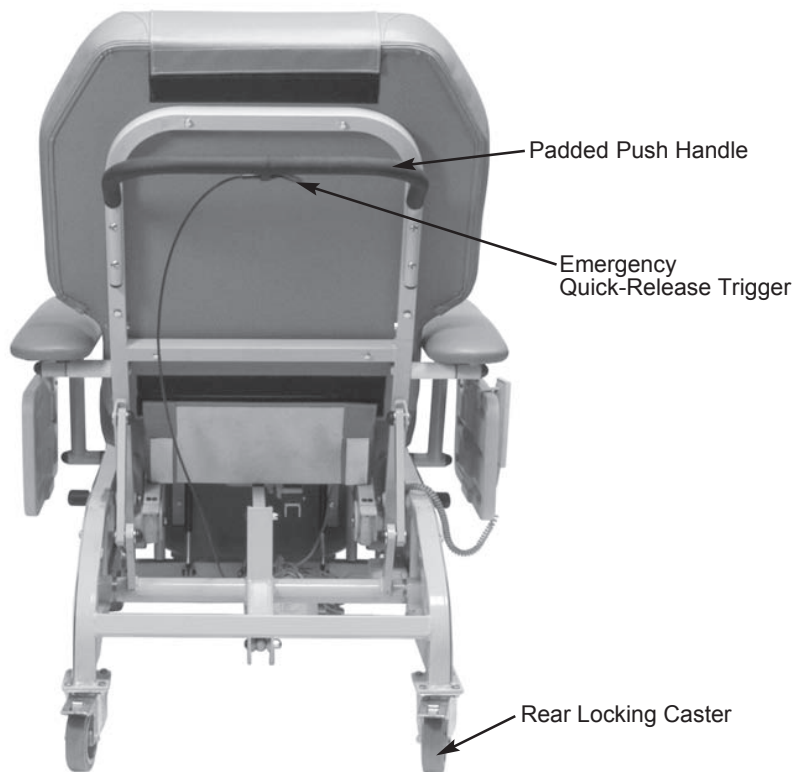

Figure 2

Hardware Included	
Description	Qty
Bolt with 1/2" hex head	4
Bolt with 7/16" hex head, split washer	2
Screw with M5 socket head	4
M5 hex key	1
Tools Needed	
Socket wrench for 1/2 & 7/16 hex head bolts	1

ASSEMBLY



Figure 4



Figure 5

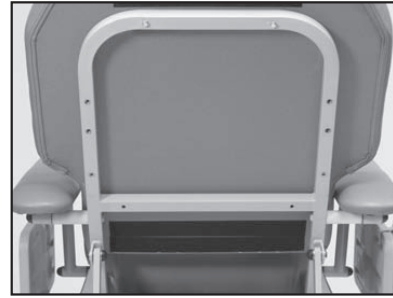

Figure 6

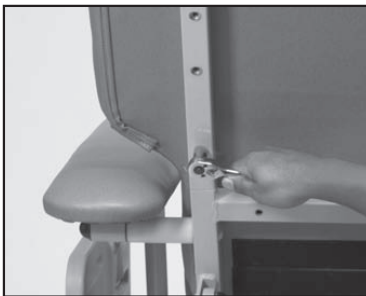

Figure 7



Figure 8



Figure 9



Figure 10

Unpacking

1. Check for obvious damage to the carton or its contents. If damage is evident, please notify the carrier and your Graham-Field authorized distributor.
2. Remove all packaging materials from recliner base.

Setup

1. Plug the recliner's power cord into a properly grounded electrical wall outlet. Using the hand control pendant, raise the back fully into the upright position (Fig. 4).
2. Align the tubes on the backrest with back support tubes on the mainframe assembly (Fig. 5). Place the backrest onto the support tubes until the holes on the back are aligned with the threads of the inner nuts (Fig. 6).
3. Attach and fully tighten all 1/2" and 7/16" bolts to the back support bars with a wrench (Fig. 7, Fig. 8).
4. Align the holes on the push bar with the holes on the back bar. Attach socket head screws to the push bar and fully tighten with supplied hex key (Fig 9). Repeat until push bar is tightly secured to the backrest (Fig. 10).

Footboard Installation

1. Align attachment arms of footboard assembly inside the hinges on the crossbar located behind the legrest upholstery. Ensure that the holes on each hinge are aligned with the holes on the attachment arms of the footboard.
2. Insert one bridge pin through the holes on one hinge and attachment arm (Fig. 11).
3. Insert the cotter clip into the hole on the bridge pin so that the attachment is secure (Fig. 12).
4. Repeat steps 2 and 3 for the other side.



Figure 11



Figure 12

OPERATION

⚠ WARNING: Disconnection of this device: In case of emergency, always disconnect the device by removing the power cord plug from the power outlet.

Seat Positioning: Shock Position

With the exception of the Shock Position, all seat positioning must be controlled by the hand pendant.

SHOCK POSITION: To attain shock position from any position, grasp the push handle with one hand while actuating the emergency quick-release trigger with the other (see picture at right), then guide the back down fully and release the trigger.

To return to seated position: Press the “up” button on the hand control until the backrest is in the upright position.

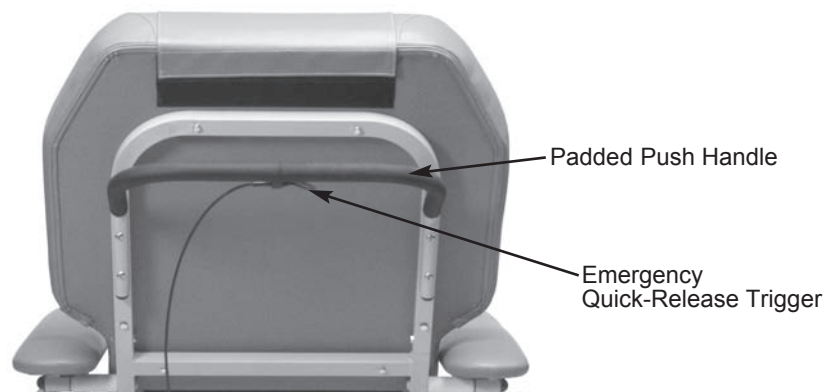

Figure 2 detail

Seat Positioning: Hand Pendant

All seat positioning, with the exception of the Shock Position, must be controlled by the hand pendant.

The hand pendant has four buttons that control the positioning of the chair. The two top buttons control the backrest and the two bottom buttons control the legrest (Fig. 13).



Figure 13

Caster Operation

⚠ WARNING: Caster wheels must be locked except during transport.

Info: This recliner is equipped with four swivel casters for improved maneuverability. The rear casters are also equipped with locking features.

To lock rear caster: To prevent the rear casters from swiveling and the wheel from turning, step on the rear pedal of the caster until it latches.

To unlock rear caster: Step on middle button to unlatch.

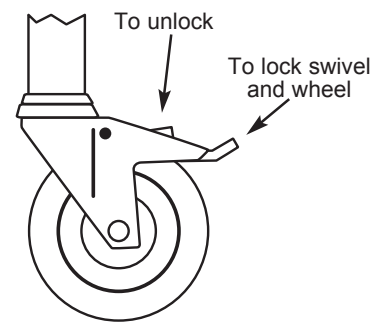

Figure 14

Table Operation

To raise table: Raise the table all the way up and slide in toward the armrest until tabs engage slots in mount bracket. Press down lightly on table to ensure lock tabs are engaged.

To lower table: Lift table up until tabs disengage slots and pull table away from armrest and lower table to self-storing position.

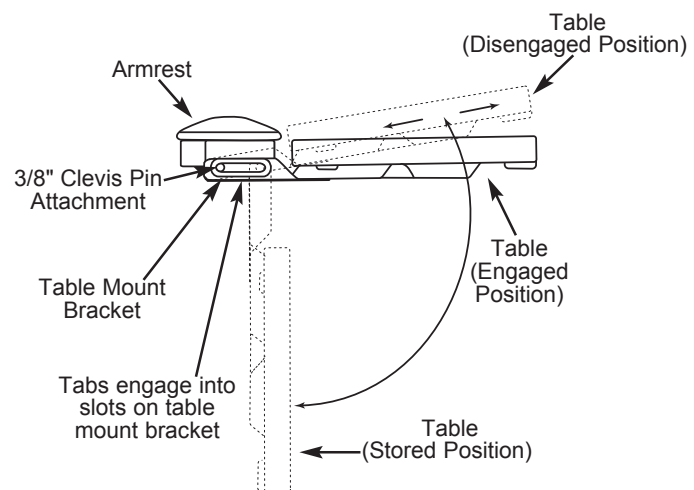



Figure 15

PRODUCT SPECIFICATIONS

Meets CA-TB133 Specifications	Flame and stain resistant vinyl upholstery	
Power	120Vac, 60 Hz, Max. 2.7 A	
Class	Class 1 Equipment; Type B	
Total Weight	264 lb. (120 kg)	
Overall Dimensions	54.06" H x 57.95" L x 36.89" W (1373 mm H x 1472 mm L x 937 mm W)	
Maximum Weight Capacity for Motorized Recliner	Recliner: 700 lb. (318 kg), EVENLY DISTRIBUTED	
	Upholstered Back: 440 lb. (200 kg), EVENLY DISTRIBUTED	
	Upholstered Seat: 660 lb. (300 kg), EVENLY DISTRIBUTED	
	Upholstered Armrest: 110 lb. (50 kg), EVENLY DISTRIBUTED	
	Upholstered Legrest: 110 lb. (50 kg), EVENLY DISTRIBUTED	
	Side Table: 22 lb. (10 kg), EVENLY DISTRIBUTED	
	All weight capacities and maximum loads are to be evenly distributed over component / product as described above.	
Applied Parts	Upholstered Back, Upholstered Headrest, Upholstered Seat, Upholstered Armrest, Side Table, Upholstered Legrest, and Footrest	
Operator Accessible Parts	Applied Parts, Power Supply Cord, Pendant Control, Padded Push Handle, and Switch Wheels Assembly	
Operation Environment (Normal Use)	An ambient temperature range of 50°F to 104°F (10°C to 40°C)	
	A relative humidity range of 30% to 75%	
	An atmospheric pressure range of 10.15 psi to 15.37 psi (70 kPa to 106 kPa)	
Transport and storage	This equipment shall be capable, while packed for transport or storage, of being exposed for a period not exceeding 15 weeks to environmental conditions not outside the following ranges:	an ambient temperature range of -4°F to +140°F (-20°C to +60°C)
		a relative humidity range of 0% to 85%, including condensation
		an atmospheric pressure range of 7.25 psi to 15.37 psi (50 kPa to 106 kPa)
Disposal	Follow all applicable federal, state, and local laws and regulations to dispose of the unit.	
	MEDICAL EQUIPMENT WITH RESPECT TO ELECTRICAL SHOCK, FIRE AND MECHANICAL HAZARDS ONLY IN ACCORDANCE WITH UL 60601-17	

MAINTENANCE

⚠ WARNING: Inspect all components periodically and replace as needed.

Cleaning

Recliner upholstery requires little maintenance. Everyday dirt can usually be removed using a clean, soft cloth or sponge with mild soap and water. Spills and accidents require immediate attention for best results.

Always begin cleaning by using steps 1 or 2, then progress to the stronger cleaners if needed. Most soil can be easily removed with soap and water or the concentrated cleaners suggested in step 2. If use of a disinfectant is desired, the Centers for Disease Control and Prevention recommends using a solution consisting of 1/4 cup of bleach to 1 gallon of water, then rinsing the solution thoroughly from the surface with clear water. Not rinsing thoroughly and/or using stronger mixtures will likely result in discoloration of the upholstery.

Staining Agent	Step	Cleaning Procedure
Eye Shadow / Mascara	1	Remove excess spill with clean, damp cloth. Clean with a 1:1 solution of mild dish detergent (such as Ivory® liquid) and water. Rinse with clear water and dry with a clean cloth.
Grease / Suntan Lotion / Chocolate		
Crayon / Black Felt Tip Pen		
Blood / Urine / Feces	2	Use undiluted application of concentrated antibacterial cleaner (such as Formula 409® or Fantastik® Spray Cleaner), then wipe with a clean cloth.
Red Lipstick		
Oil Base Paint / Tar / Asphalt	3	Use a 1:1 solution of ammonia and water or a 1:4 solution of bleach and water, rinse with clear water, and dry with a clean cloth.
Other Tough Stains	4	Use undiluted application of naphtha (lighter fluid). Saturate a soft, clean cotton cloth with this solution. Rub the stain in a circle 10 times. Rinse thoroughly with clear water. Use another soft, clean cotton cloth to pat surface dry. Check results. If stain remains, proceed to step 5.
	5	Use 1:1 solution of isopropyl alcohol and water. Saturate a soft, clean cotton cloth with this solution. Rub the stain in a circle 10 times. Rinse thoroughly with clear water. Use another soft, clean cotton cloth to pat surface dry. Check results. If stain remains, use undiluted isopropyl alcohol. Saturate a soft, clean cotton cloth with this solution. Rub the stain in a circle 10 times. Rinse thoroughly with clear water. Use another soft, clean cotton cloth to pat surface dry. Check results. If stain remains, use 1:1 solution of acetone and water. Saturate a soft, clean cotton cloth with this solution. Rub the stain in a circle 10 times. Rinse thoroughly with clear water. Use another soft, clean cotton cloth to pat surface dry.

LIMITED WARRANTY

SCOPE OF WARRANTY

GF Health Products, Inc. ("GF") warrants to the original purchaser only that it will replace or repair components, at GF's sole discretion, that are defective in material or workmanship under normal use and service. All warranties are conditioned upon the proper use of the products strictly in accordance with good commercial practice and applicable GF instructions and manuals, including proper use and maintenance. To the extent that a component is warranted by a third party, GF conveys all of its rights under that warranty to the original purchaser, to the extent permitted.

This limited warranty shall only apply to defects that are reported to GF's customer service team within the applicable warranty period and which, upon examination by GF or its authorized representative, prove to be a warranty item. This limited warranty is not transferable.

The warranted components and time period are set forth below:

- Frame: ten years
- Upholstery: one year
- Electronics, motors, electrical components: one year
- All other durable components not listed above: . . . three years

The applicable warranty period shall commence from date of shipment to the original customer, unless there is an expiration date on the component in which case the warranty shall expire on the earlier of warranty period or the expiration date.

OBTAINING WARRANTY SERVICE

A GF Customer Service Representative must authorize warranty service. Please contact the GF Customer Service department by calling 678-291-3207, sending a fax request to 770-368-2386 or by e-mailing a request to cs@grahamfield.com. Specific directions will be provided by the Customer Service Representative. Failure to abide by the specific directions will result in denial of the warranty claim.

EXCLUSIONS

The warranty does not cover and GF shall not be liable for the following:

- 1) Defects, damage, or other conditions caused, in whole or in part, by misuse, abuse, negligence, alteration, accident, freight damage, tampering or failure to seek and obtain repair or replacement in a timely manner;
- 2) Products which are not installed, used, or properly cleaned and maintained as required in the official manual for the applicable product;
- 3) Products considered to be of a non-durable nature including, but not limited to: casters, filters, fuses, gaskets, lubricants, and charts;
- 4) Accessories or parts not provided by GF;
- 5) Charges by anyone for adjustments, repairs, replacement parts, installation or other work performed upon or in connection with such products which are not expressly authorized in writing, in advance, by GF;
- 6) Any labor or shipping charges incurred in the replacement part installation or repair;
- 7) Costs and expenses of regular maintenance and cleaning; and
- 8) Representations and warranties made by any person or entity other than GF.

ENTIRE WARRANTY, EXCLUSIVE REMEDY AND CONSEQUENTIAL DAMAGES DISCLAIMER

THIS WARRANTY IS GF'S ONLY WARRANTY AND IS IN LIEU OF ALL OTHER WARRANTIES, EXPRESS OR IMPLIED. GF MAKES NO IMPLIED WARRANTIES OF ANY KIND INCLUDING ANY IMPLIED WARRANTIES OF MERCHANTABILITY OR FITNESS FOR A PARTICULAR PURPOSE.

IF ANY MODEL OR SAMPLE WAS SHOWN TO THE CUSTOMER, SUCH MODEL OR SAMPLE WAS USED MERELY TO ILLUSTRATE THE GENERAL TYPE AND QUALITY OF THE PRODUCT AND NOT TO REPRESENT THAT THE PRODUCT WOULD NECESSARILY CONFORM TO THE MODEL OR SAMPLE IN ALL RESPECTS.

THIS WARRANTY IS LIMITED TO THE REPAIR OR REPLACEMENT OF THE DEFECTIVE PARTS. GF SHALL NOT BE LIABLE FOR AND HEREBY DISCLAIMS ANY DIRECT, SPECIAL, INDIRECT, INCIDENTAL, EXEMPLARY OR CONSEQUENTIAL DAMAGES, INCLUDING, BUT NOT LIMITED TO: DAMAGES FOR LOSS OF PROFITS OR INCOME, LOSS OF USE, DOWNTIME, COVER, OR EMPLOYEE OR INDEPENDENT CONTRACTOR WAGES, PAYMENTS AND BENEFITS.

The warranties contained herein contain all the representations and warranties with respect to the subject matter of this document, and supersede all prior negotiations, agreements and understandings with respect thereto.

The recipient of this document hereby acknowledges and represents that it has not relied on any representation, assertion, guarantee, warranty, collateral contract or other assurance, except those set out in this document.

For additional information on this product or this warranty, please contact a GF Customer Service Representative.

NOTES:

- 1) Additional terms and conditions may apply.
- 2) Freight claims must be notated on the Bill of Lading and must be made with immediacy. The ICC regulations govern specific requirements for freight claims. Failure to abide by those regulations may result in a denial of the freight claim. GF will assist you in filing the freight claim.
- 3) Claims for any short shipment must be made within thirty (30) days of the invoice date.

Manufactured for:
GF Health Products, Inc.
2935 Northeast Parkway
Atlanta, Georgia 30360 USA
Telephone: 770-368-4700
Fax: 770-368-2386
Technical Support: 770-447-1609



GRAHAM-FIELD
www.grahamfield.com

Made in Taiwan